

Relingbefestigung Pipe Fixture BE/R 170

Best.-Nr.: 109 278
O.-No.: 109 278

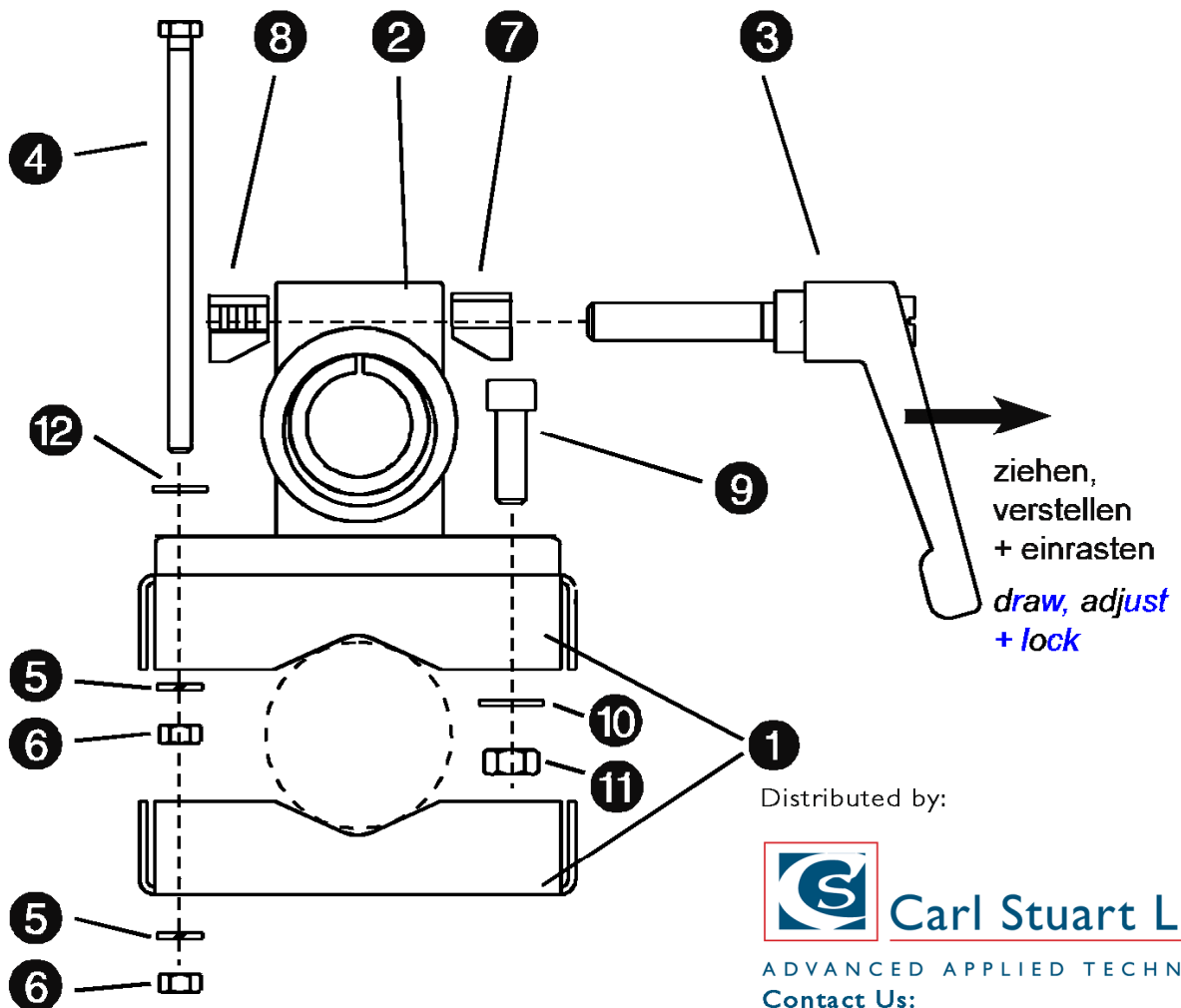

Carl Stuart Limited

ADVANCED APPLIED TECHNOLOGIES

Contact Us:

Irl Ph: 01 4523432

UK Ph: 08452 30 40 30

Web: www.carlstuart.com

Email: info@carlstuart.com

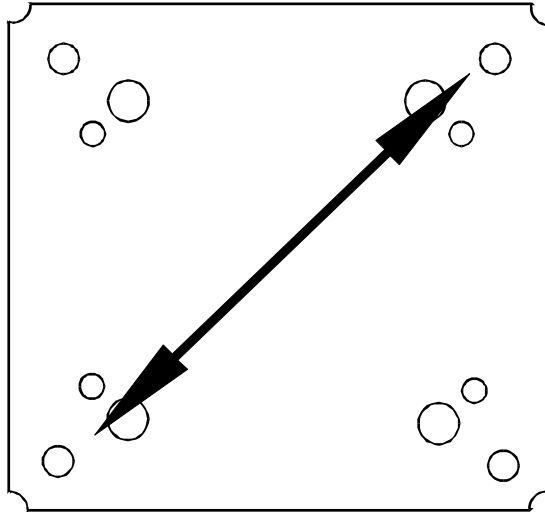

- Zur **Montageerleichterung** zwei Sechskantschrauben ④ mit Fächerscheibe ⑫, Federring ⑤ und Mutter ⑥ an einer Klemmschale ① diagonal vormontieren.
 - Flanschklemmstück ② mit Zylinderschrauben ⑨, Beilagscheiben ⑩ und Muttern ⑪ (je 4 x) an die Klemmschale montieren.
 - Klemmhebel ③ montieren,
 - Beide Klemmschalen wie in der Abbildung gezeigt am Rohr befestigen.
-
- For **easy assembly** pre-assemble two hexagon head screws ④ with lock washer ⑫, spring washer ⑤ and nut ⑥ diagonally at one clamping shell.
 - Assemble flange shim ② with cheese-head screws ⑨, shims ⑩ and nuts ⑪ (each 4 times) to the clamping shell.
 - Assemble clamping lever ③.
 - Fix both clamping shells at the tube as shown in the drawing.

Lieferumfang
Equipment consists of

BE/R 170

Position	Bezeichnung <i>Article</i>	Menge <i>Quantity</i>
①	Klemmschale <i>Clamping shell</i>	2
②	Flanschklemmstück mit Reduzierstück <i>Flange shim with reducer</i>	1
③	Klemmhebel M8 x 50 <i>Clamping lever M8 x 50</i>	1
④	Zylinderschraube M6 x 110 <i>Cheese-head screw M6 x 110</i>	4
⑤	Federring 6.5 <i>Spring washer 6.5</i>	6
⑥	Mutter DIN 934 M6 <i>Nut DIN 934 M6</i>	6
⑦	Klemmkeil ohne Gewinde <i>Clamping wedge without thread</i>	1
⑧	Klemmkeil mit Gewinde <i>Clamping wedge with thread</i>	1
⑨	Zylinderschraube M8 x 25 <i>Cheese-head screw M8 x 25</i>	4
⑩	Beilagscheibe 8.4 <i>Shim 8.4</i>	4
⑪	Mutter M8 <i>Nut M8</i>	4
⑫	Fächerscheibe A 6.4 <i>Lock washer A 6.4</i>	4

Position	Material
①, ④ - ⑫	Edelstahl 1.4301 <i>Stainless steel 1.4301</i>
②	Aluminium-Druckguß <i>Aluminium die-cast</i>
③	Aluminium-Druckguß / Edelstahl 1.4301 <i>Aluminium die-cast / Stainless steel 1.4301</i>



Wissenschaftlich-Technische Werkstätten GmbH

Dr.-Karl-Slevogt-Straße 1
D-82362 Weilheim

Germany

Tel: +49 (0) 881 183-0
 +49 (0) 881 183-100
Fax: +49 (0) 881 183-420
E-Mail: Info@WTW.com
Internet: <http://www.WTW.com>